

Maguire Products – Gravimetric Blender Data Sheet

Weigh Scale Blender – WSB 941P Blender

Design

The WSB 941 consists of 1 fixed hopper with 4 material compartments fitted with 4 Slide gates for materials with large percentages and 1 Removable Auger Feeder fitted with a 1" Screw for metering small percentages of powders. The materials hopper is mounted on a compact and robust steel frame.

Operation

- ❖ Each component is dispensed in turn through pneumatic slide gates and the auger feeder.
- ❖ Before the batch commences and after each dispense is made the Controller takes a weight reading to ensure complete accuracy for the materials settings made.
- ❖ The materials are dispensed in turn onto a central weigh bin mounted on two load cells.
- ❖ Each batch is limited by the capacity of the weigh bin at 9000g per batch.
- ❖ When each batch is completed it is released into the mixing chamber.
- ❖ Material levels in the mixing chamber are controlled by a level sensor mounted in the upper part of the mix chamber.
- ❖ When the level of material in the chamber covers the sensor the Control System will pause the blender to ensure consistent and good mixing.
- ❖ Once the blended material level falls below the sensor, the cycle is repeated.
- ❖ Material Dispenses are regulated by the Control System that continuously monitors the set percentages.
- ❖ The Control System ensures that the material settings made remain within tight tolerances. If variations in bulk density occur the Control will automatically adjust dispenses to meet the target settings.
- ❖ Settings are made easily by simply dialling in the percentages of each component on thumbwheels.
- ❖ Alternatively the password access keypad can be used to ensure only authorised personnel to can set, reverse or restrict thumbwheel settings.
- ❖ The flexible software offers a wide range of other functions and can easily be set using the password controlled keypad.
- ❖ Data retrieval is freely available with data available by viewing on the controller screen, connecting a standard printer or by using the Maguire MLAN software that allows you to connect a Computer to the blender.

Options

MECN – Maguire Extrusion Control Network

The blender can be integrated with an extruder to control the extruder speed to ensure consistent kg/hr output. This improves quality, control, and efficiency and reducing materials costs.

G2 – Maguire Data Software The blender can be linked to 1 computer to send and retrieve material settings and recipes and provide important material consumption reports for quality control, costs and easy reference on production.

FCA – Flow Control Assembly A separate product is available to mount below the blender when it is not mounted directly on the throat. This ensures good mixing and a consistent blend of material.

VTA-9 Blender Stands Maguire can supply a stand with material bin (capacity 114Kg) to mount the blender remotely.

For further information on the extensive range Products and Options from Maguire visit www.maguire.com.

Warranty

All Maguire products are covered by a 5 year parts warranty. This is the most comprehensive warranty in the Industry.

Compliance – CE & Year 2000

The Maguire blender is fully CE certified and meets all the requirements for Year 2000 compliance.

Technical Summary

Model	WSB 941P
Maximum Throughput	900 Kg/hr
Number of Materials	5
Material Dispense System	4 Slide Gates 1 1" Powder Feeder
Weight	209 Kg
Power Supply	240 V - Controller 480 V - Mix Motor
Compressed Air Pressure	6 – 8 Bars
Compressed Air Usage	0.3 m ³ /hr

Shipping Data

Shipping Weight	239Kg
W x H x D	H212 x 140 x 80

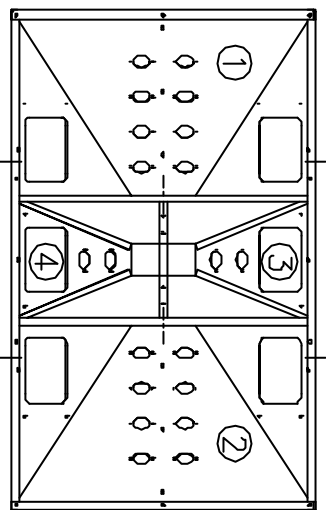
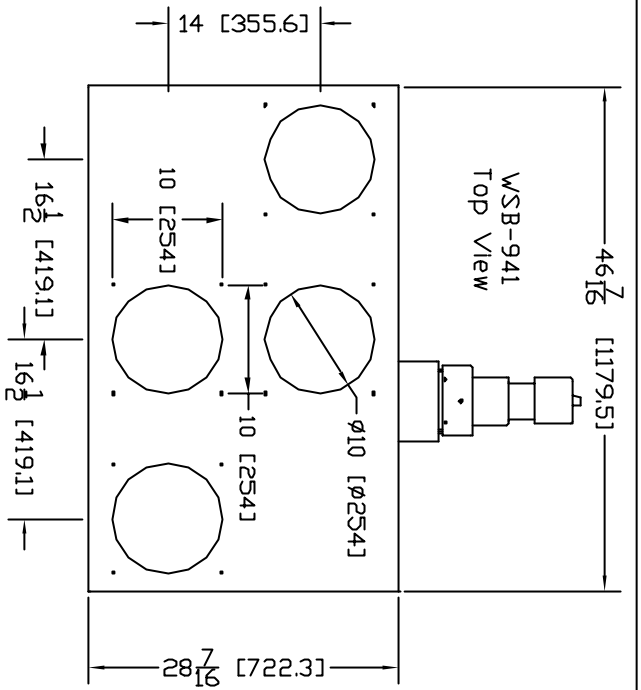

WSB 941 HOPPER-TOP VIEW

- MODEL WSB-941
- * COMPARTMENTS 1 & 2 - 3 CU. FT. [84 LITRE]
 - * COMPARTMENTS 3 & 4 - 1 CU. FT. [28 LITRE]
 - * ADDITIVE FEEDER HOPPER - .5 CU. FT. [14 LITRE]

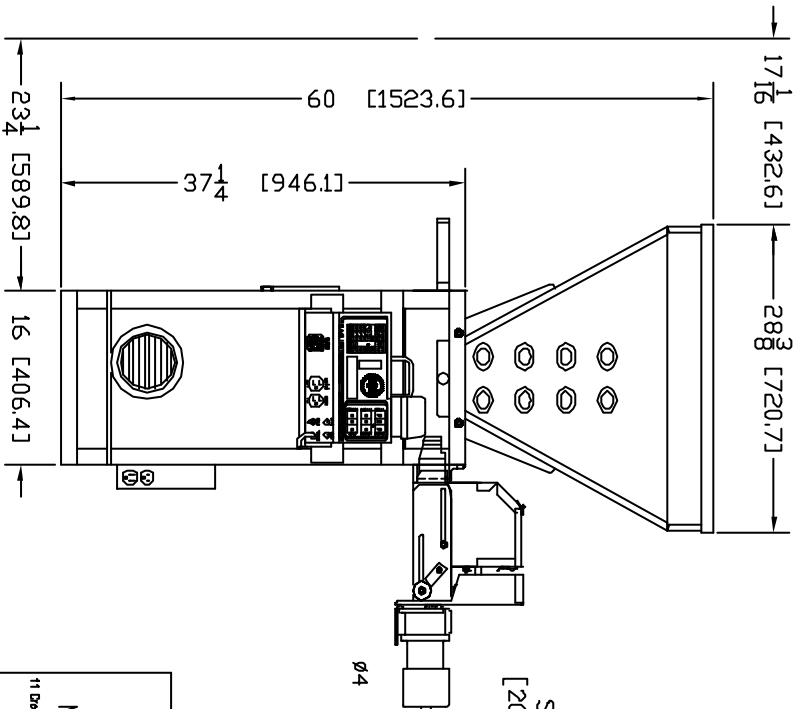
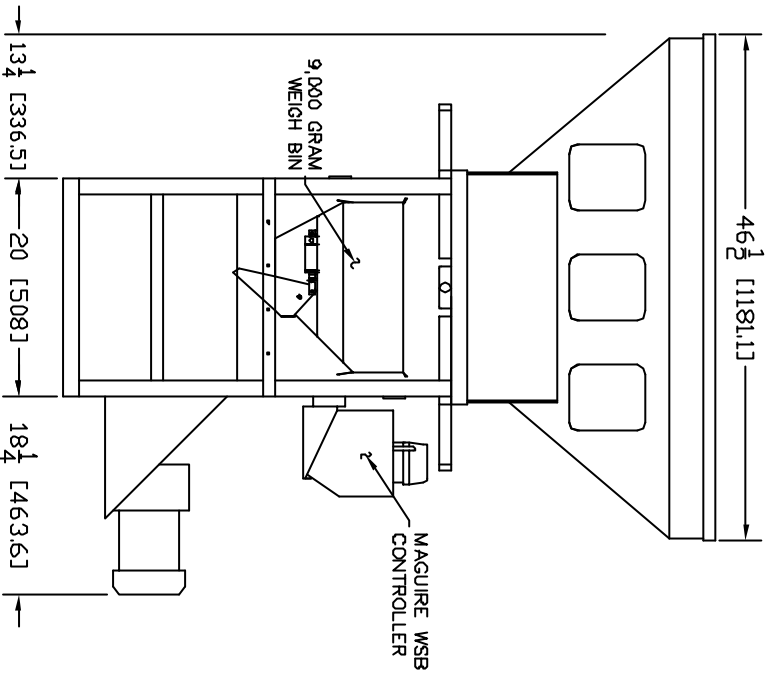

WSB-941
FOOTPRINT

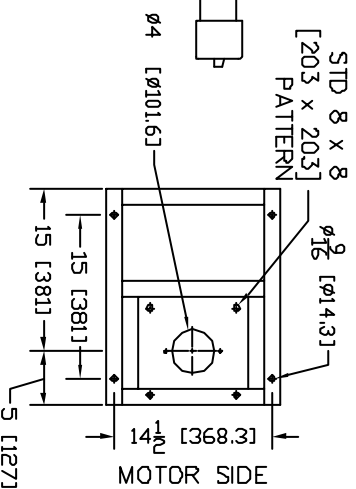

STD 8 x 8
[203 x 203]
PATTERN

Ø4 [101.6]

MOTOR SIDE



MAGUIRE
PRODUCTS, INC.
11 Dorothea Road, Lake, PA 16044
Tel: (800) 498-2412
Fax: (412) 536-2700
http://www.maguire.com

MAGUIRE WEIGH
SCALE BLENDER
MODEL WSB-941

DATE DRAWN
2/15/00

DRAWN BY
CGC

DATE CHANGED

SHEET
1 OF 1