



## Vacuum Station SVS-I



### Three phase vacuum station for conveying of Free-Flowing Granules

- Functional, compact design
- User-friendly control including control for ratio-valve and line cleaning valve
- Available in different sizes able to meet any production need
- Including central filter and cooling valve
- Solutions for dust separation (option)
  - o cyclone
  - o self-cleaning filters
  - o blow-back
- Frequensregulation
  - o Energy savings
  - o Protect plastic granules
  - o Optimized operation

## Vacuum Station, SVS-I - Dimension Sketch

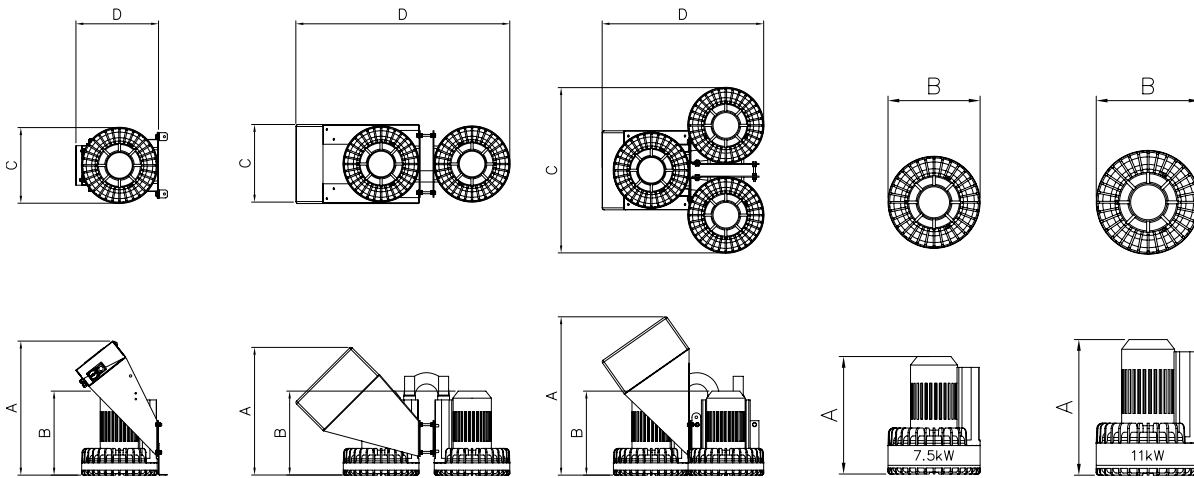

Type	A	B	C	D
1xLT6	685	430	390	425
2xLT6	650	430	400	1100
3xLT6	810	430	850	825
7,5	650	510		
11	750	575		

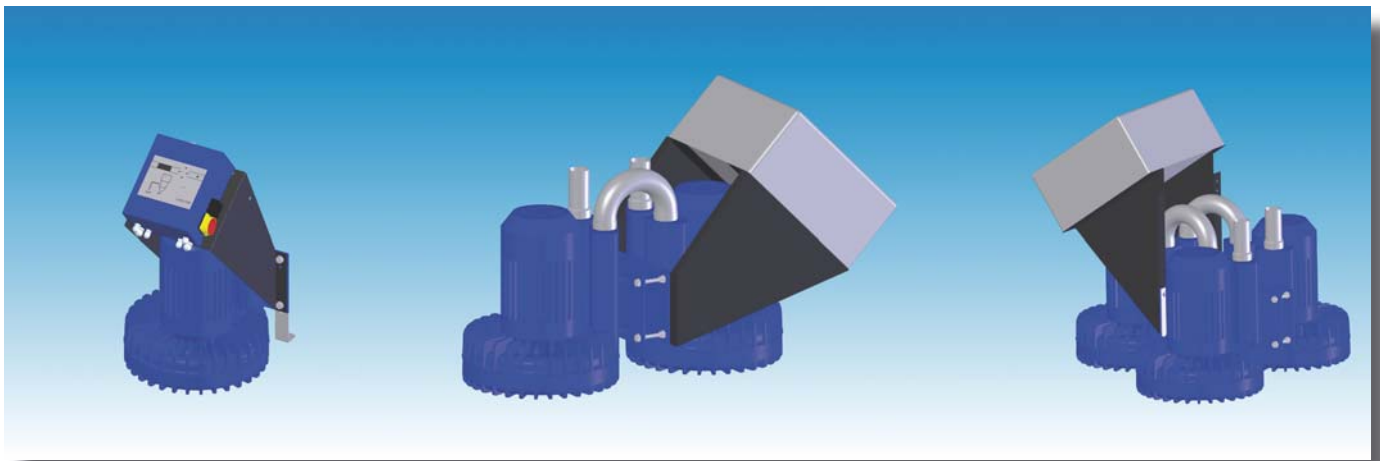

Labotek A/S  
 Strøbjergvej 29  
 DK-3600 Frederikssund  
 Tel: +45 4821 8411  
 Fax: +45 4821 8000  
 E-mail: info@labotek.com  
 www.labotek.com

Manufacturer's Representative: