



SVR-I Powder Vacuum Hopper Loader



Automatic Vacuum Conveyung of Free- Flowing Plastic Granules

- Automatic level control.
- 3-phase motor.
- Available in sizes from 50 to 200 litre.
- Low level alarm.
- Automatic filter cleaning by compressed air.
- Low noise level.
- Execution in stainless steel.
- Blower with capacities ranging from 1,3 to 11 kW.
- Easy installation.

Technical specifications	SVR-I Powder
Power supply	3~50/60Hz, 220-480 V
Motor power, kW.	1,3 - 11
Motor r.p.m., min.	2860/3460
Air volume, m ³ /h.	210/300
Noise level, dBA	71-72
Vacuum hopper, capacity/litre	50 - 200
Conveying hose, inner diameter, mm.	50,8/63,5
Conveying hose, length, m.	4
Connection cable, m.	5
Telescopic suction probe	
Outer pipe, length, mm.	700
Outer pipe, outer diameter, mm.	50,8/63,5
Inner pipe, length, mm.	840
Inner pipe, diameter mm.	76,2/89



SVR-I Powder
Vacuum Hopper Loader
Are also available in special version
(with comp. air slide valve and ATEX
sensor).

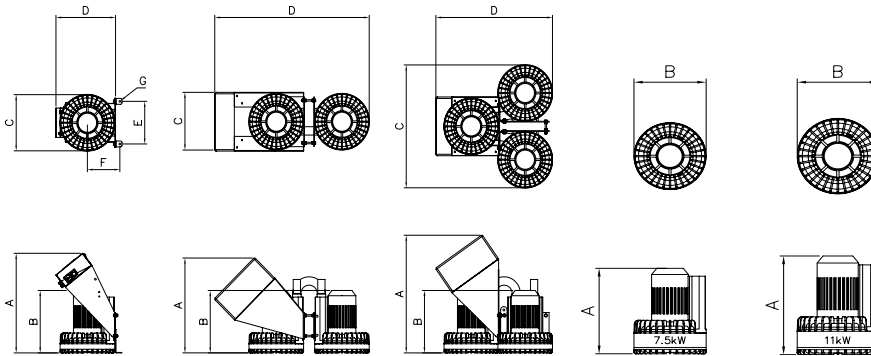

Type	A	B	C	D	E	F	G
1xLT5	665	395	340	470	260	207,5	ø11
1xLT6	685	430	390	425	290	227,5	ø11
2xLT6	650	430	400	1100	-	-	-
3xLT6	810	430	850	825	-	-	-
7,5kW	650	510	-	-	-	-	-
11kW	750	575	-	-	-	-	-

All measurements are in mm.



Labotek A/S
Strøbjergvej 29
DK-3600 Frederikssund
Tel: +45 4821 8411
Fax: +45 4821 8000
E-mail: info@labotek.com
www.labotek.com

Manufacturer's Representative:



Flange dimension
Flanch masse
Flange mål

