



SVR-I 75 - 200 Stainless Steel Vacuum Conveyor



Stainless Steel Vacuum Conveyor Conveying Large Volumes Free-Flowing Granules

- 4 sizes SVR Hopper; 75, 100, 150, and 200 Litre
- Execution in stainless steel
- Designed for continuous operation
- Robust design
- Effective filter system
- Supplied complete with vacuum blower, suction probe, hose, and separate control
- Blowers from 3.4 -15 kW

Type	SVR75	SVR100	SVR150	SVR200
A	Ø420	Ø420	Ø600	Ø600
B	1220	1340	1222	1447

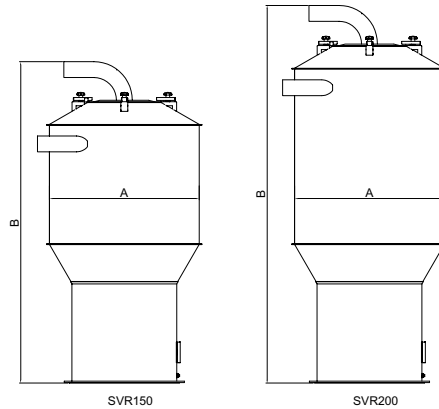
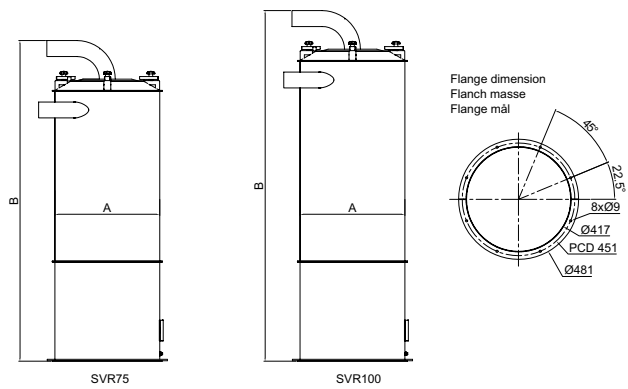

R2326_R00

Type	A	B	C	D
1xLT6	685	430	390	425
2xLT6	650	430	400	1100
3xLT6	810	430	850	825

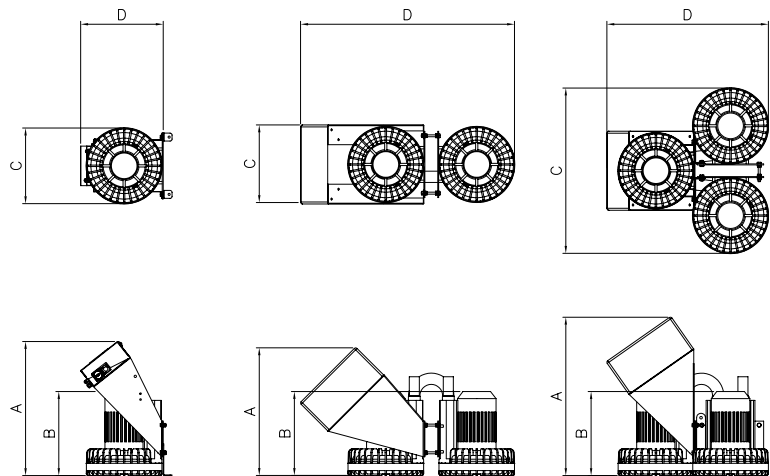

Labotek A/S
 Strøbjergvej 29
 DK-3600 Frederikssund
 Tel: +45 4821 8411
 Fax: +45 4821 8000
 E-mail: info@labotek.com
 www.labotek.com

Manufacturer's Representative: