

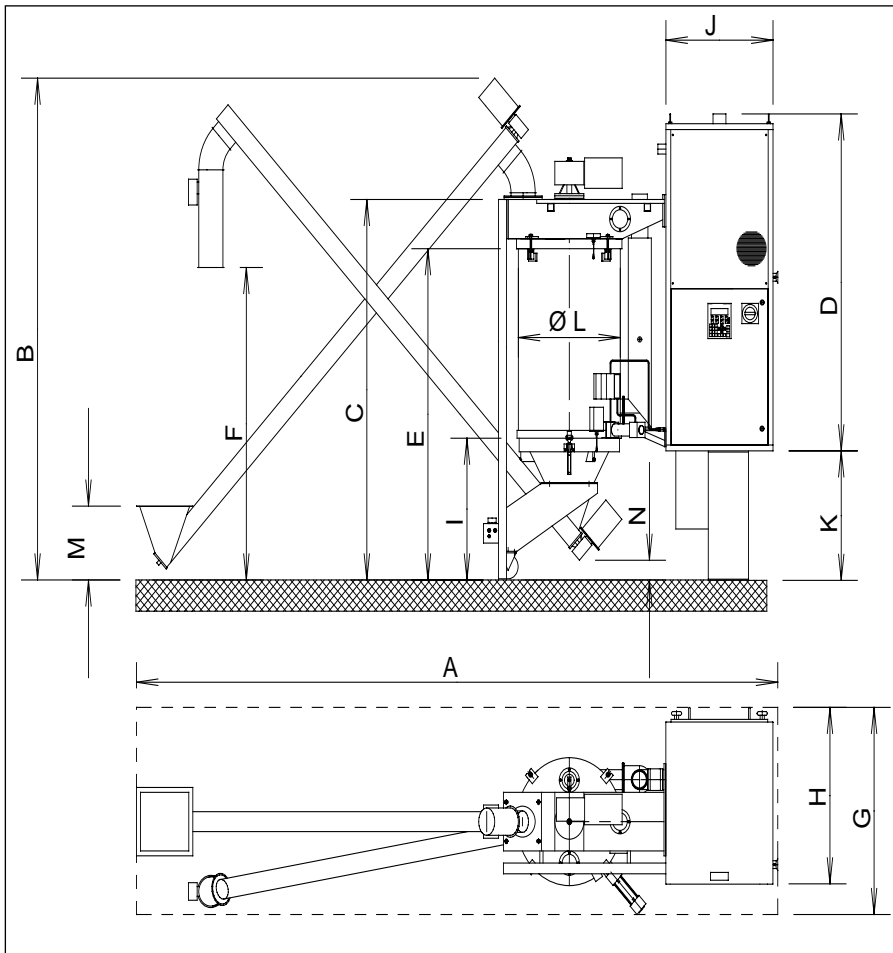

## PET Solution



- Batch control eliminates cross contamination of amorphous and crystalline material
- Process control temperature, airflow gives optimum energy efficiency and crystallization consistency
- Small crystallization chamber gives shorter process time and increased flexibility
- Compact design minimizes footprint
- Clean and minimum of dust after crystallization
- Fast crystallizing cycle
- Quick material and colour change
- Easy to operate
- Proven, reliable design



**Crystallizer with Screw Conveying**  
All Measurements in mm

| Type | CC 80-S | CC 160-S |
|------|---------|----------|
| A    | 3985    | 5200     |
| B    | 2570    | 3600     |
| C    | 1948    | 2475     |
| D    | 1725    | 2205     |
| E    | 1700    | 2225     |
| F    | 1600    | 1650     |
| G    | 1060    | 1220     |
| H    | 905     | 1169     |
| I    | 725     | 1005     |
| J    | 665     | 990      |
| K    | 663     | 905      |
| L    | ø633    | ø593     |
| M    | 380     | 700      |
| N    | 100     | 150      |

**Crystallizer with Vacuum Conveying**  
All Measurements in mm

| Type | CC 80-V | CC 160-V |
|------|---------|----------|
| A    | 3120    | 3630     |
| B    | 1948    | 2475     |
| C    | 1700    | 2225     |
| D    | 725     | 1000     |
| E    | 130     | 140      |
| F    | ø654    | ø654     |
| G    | ø633    | ø693     |
| H    | 665     | 990      |
| I    | 1725    | 2205     |
| J    | 663     | 905      |
| K    | 1960    | 2475     |
| L    | 960     | 1170     |
| M    | 1060    | 1225     |
| N    | ø51     | ø51      |

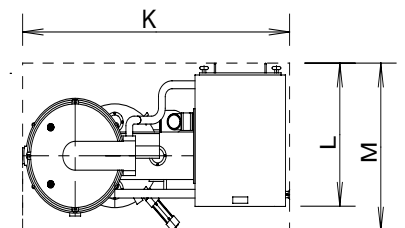
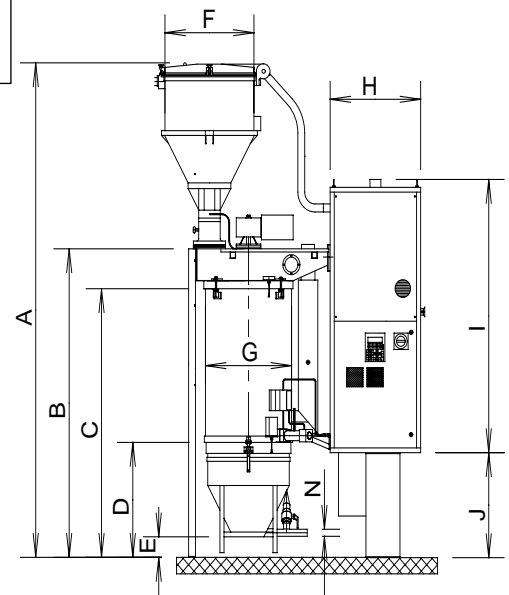

Labotek A/S  
Strøbjergvej 29  
DK-3600 Frederikssund  
Tel: +45 4821 8411  
Fax: +45 4821 8000  
E-mail: info@labotek.com  
www.labotek.com

Manufacturer's Representative: